

### 1.5" Side Pocket Piezo Pressure Gauge Carrier

#### Application

The 1.5" side pocket piezo carrier is shaped like a 1.5" gas lift valve, which allows the customer to deploy the piezo carrier the same way you would run a 1.5" gas lift valve in a side pocket mandrel. The carrier holds a 3/4" piezo memory gauge and can measure either tubing or annulus pressure. AA battery packs are used in 0.75" OD piezo gauges, which limits the duration the tool can be "on" downhole, typically no more than 2 to 3 months.

#### Features

- Shock Mounts a 3/4" Gauge - High Strength Spring, Medium Strength Spring, Elastomeric Dampener
- Annulus or Tubing Sensing
- SS17-4 or Inconel 718

#### Benefits

The biggest benefit of the 1.5" side pocket piezo carrier is a customer can deploy a gauge without interfering with the wellbore. DataCan piezo gauges also have excellent efficiency, meaning the battery life of the tool is just as good, if not better than competitors. DataCan piezo gauges have shock mounted electronics which means they have high reliability.

DataCan program and download software is industry leading with the fastest graphing package available that is both customizable and easy to use.

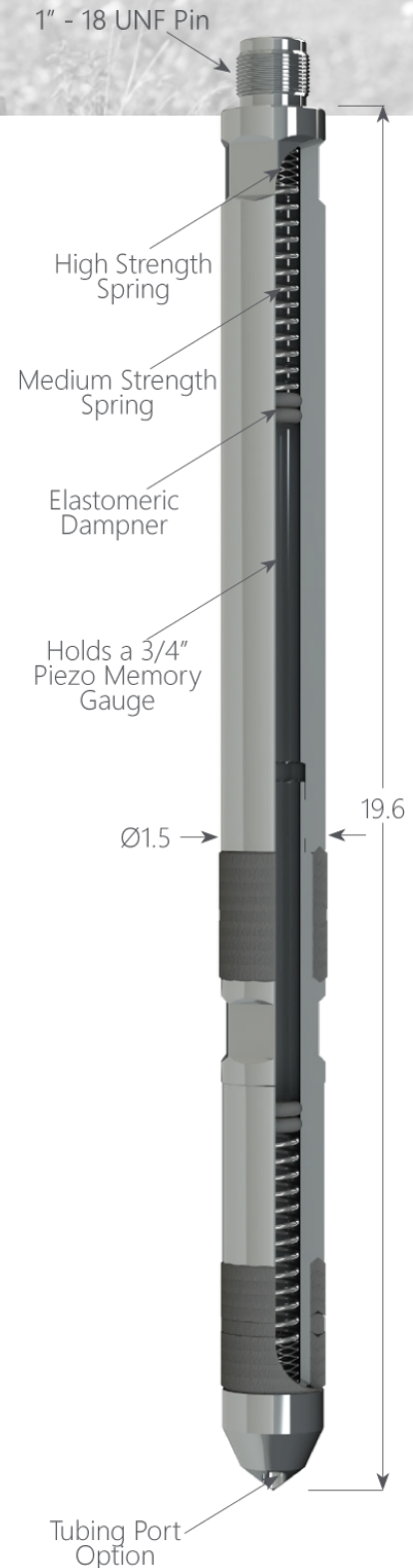

1.5" Side Pocket Piezo Carrier		
Port	Material	Part No.
Tubing	SS17-4	100157
Annulus		100163
Tubing	Inconel 718	100784
Annulus	NACE MR0175	100785

Accessories	
Accessory Type	Part No.
Pelican Case Assembly	100786
Top Latch SS316	100150
Top Latch Inconel 718	100787